

Sensata | GIGAVAC GV350 Series contactors are hermetically sealed, gas filled contactors suitable for use in harsh environments. With contact voltage ratings from 12Vdc to 1000Vdc and a hot switchable continuous carry current of 500A, the compact GV350 Series is ready to solve your next challenging application problem. Like all Sensata | GIGAVAC advanced switching solutions these contactors can be mounted in any axis or orientation and are sealed to withstand a variety of harsh environments.



Features

- Gas filled design offers lower resistance than non-hermetic switches resulting in higher system efficiency and less heat generation.
- Suppression gas allows high fault interrupt capability and prohibits oxidation.
- Smaller, lighter, and more efficient than non-hermetic switches.
- Optional auxiliary contacts for dependable feedback for HVIL circuits.
- Optional joint resistance and voltage sensing pins for easy system diagnosis.

Applications

- Battery electric vehicles
- DC fast charging
- Energy storage systems
- DC motor drive protection
- Photovoltaic controls

SPECIFICATIONS

Specifications		Units	Data
Rated Voltage ⁶		V	1000
Nominal Current		A	500
Contact Arrangement	Main	Form X	SPST-NO
	Auxiliary ¹	Form A or B	SPST-NO or SPST-NC
Mechanical Life		cycles	1,000,000
Contact Resistance	Max	mohms	0.2
	Typical	mohms	0.15
Insulation Resistance ²		Mohms	100
Dielectric at sea level (leakage < 1mA)		VRMS	4000
Shock, 1/2 Sine, 11ms	Actuated (closed)	G	50
	Non Actuated (open)	G	25
Vibration, Sinusoidal (10-2000 Hz peak)		G	25
Environmental Seal		Exceeds IP67 & IP69K	
Salt Fog		MIL-STD-810	
Short Circuit Current (20ms)		A	4000
Max Break Current @ 400V (1 cycle)		A	3000
Max Break Current @ 800V (1 cycle)		A	900

Coil Ratings at 25°C

Coil P/N Designation	P	R
Coil Voltage, Nominal (VDC)	12/24	12/24
Coil Type	External PWM ⁴	
Coil Resistance (ohms)	1.45	5
Operate Time, Max (ms) ⁵	20	
Release Time, Max (ms)	12	



POWER SWITCHING AND CURRENT CARRY RATINGS

DC POWER SWITCHING CYCLES

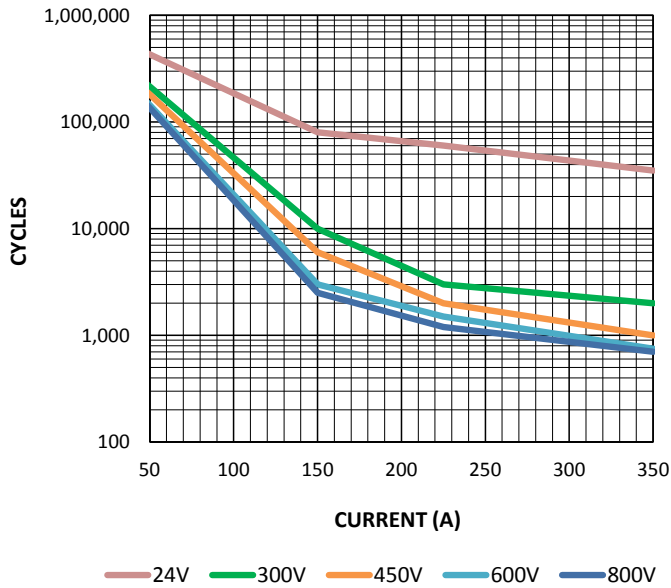

CURRENT CARRY vs TIME

with 85°C terminal temperature rise

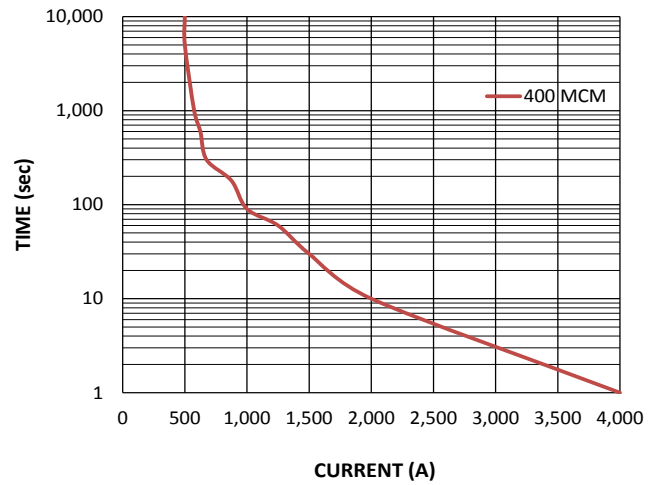



UPRIGHT MOUNT DIMENSIONS

Upright Mount

(Auxiliary with Main Terminal Connection for Sensing Voltage Across Contacts or Bolted Joint Resistance Shown)

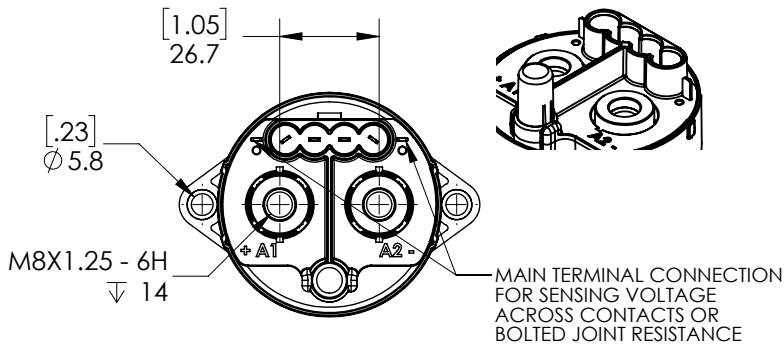

Upright Mount

(Auxiliary Shown)

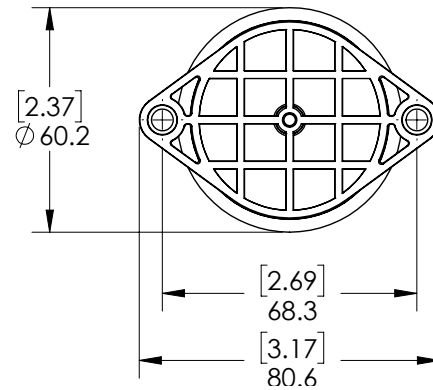
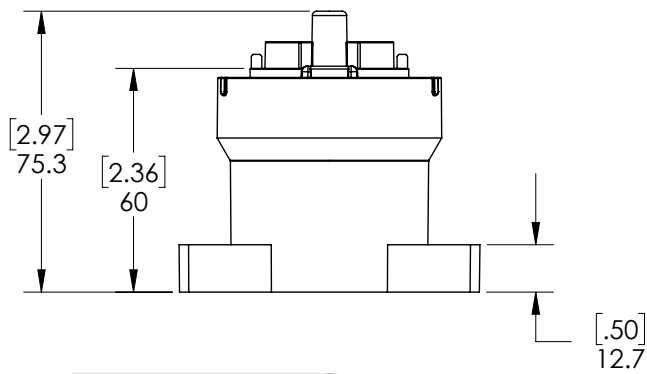
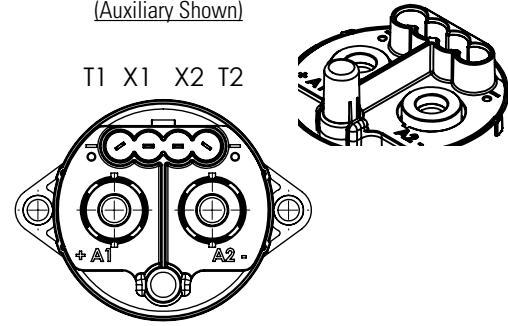



SIDE MOUNT DIMENSIONS

Side Mount

(Auxiliary with Main Terminal Connection for Sensing Voltage Across Contacts or Bolted Joint Resistance Shown)

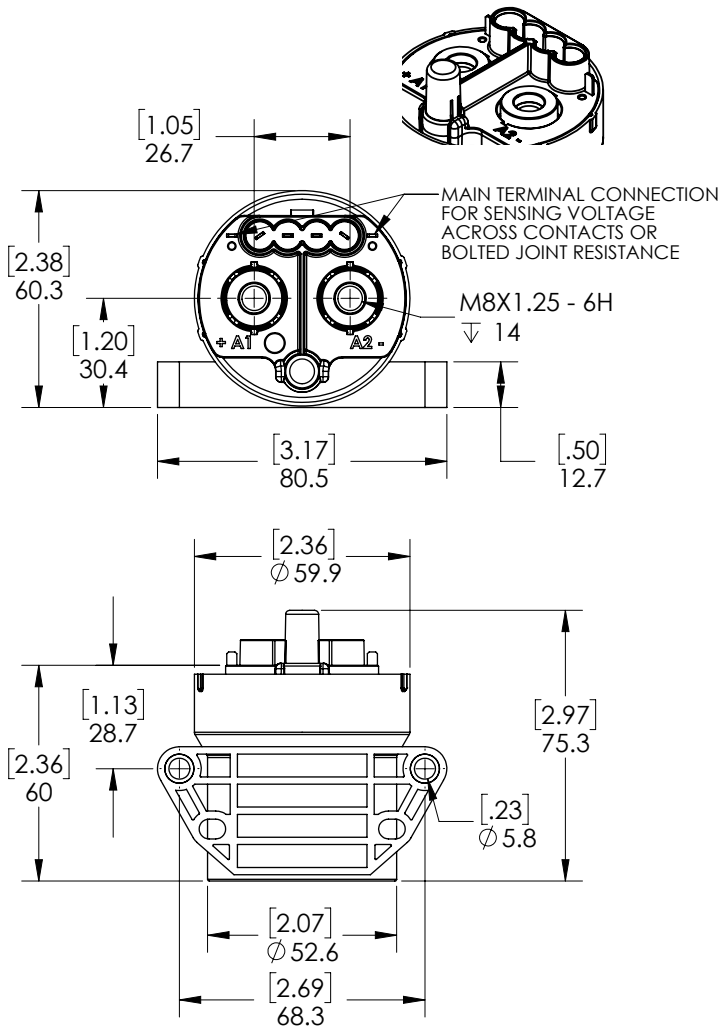

Side Mount

(Auxiliary Shown)

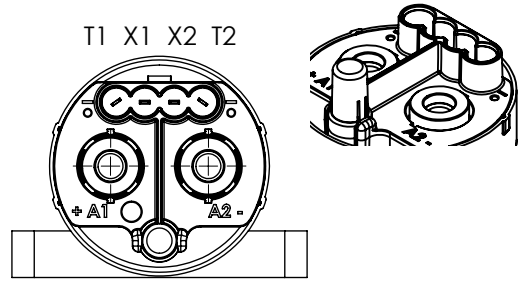

Coil/Auxiliary Connector

Coil: Tin Plated Brass
Auxiliary: Tin Plated Beryllium Copper

Mounting

M5 or No. 10 Screws
Torque 1.7-4 Nm [15-35 in-lb]

Power Connection

Silver Plated Copper M8x1.25 Terminals
Torque 10 Nm [90 in-lb] max

Auxiliary Contacts (Optional)

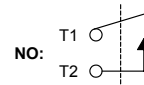

Temperature and Weight

Operating ambient Temp Range = -55 to +85°C³
Storage ambient Temp Range = -70 to +150°C
Weight, typical = 0.39 kg (0.86 lb)

Power Contacts

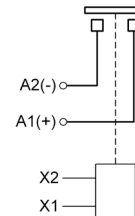

Packaging

24 units per shipping box
21 in x 18 in x 4 in shipping box



ORDERING OPTIONS

Example : GV351PPBX

	GV35	1	P	P	B	X
Family	GV35					
Mounting	1: Upright 2: Side Mount					
Coil Voltage	P: 12/24 Vdc ⁴ R: 12/24 Vdc ⁴					
Coil Termination	P: Pins					
Auxiliary Contacts	X: None B: SPST-NO Normally Open					
Voltage Sensing Pins	X: None V: Voltage Sensing Pins					



GENERAL NOTES

- Auxiliary contact rating is 2A, 24Vdc Resistive load, 100,000 cycles. Minimum current is 0.1mA, 5V. The auxiliary contact is mechanically linked to the main power contacts.
- Insulation resistance is 50 Mohms after life.
- Contactors can operate up to 125°C in special cases - contact Sensata for details.
- See Application Note [AN-022](#) for PWM instructions.
- Operation time is measured at 25°C and includes maximum 7ms bounce.
- Rated voltage refers to max voltage for which make/break load cycles are provided. Contactors can be used in higher voltage systems. Contact Sensata for more info.



TECHNICAL NOTES

- Power switching lifecycles are based on **current flow** from A1(+) to A2(-). For best breaking performance, the contactor should be installed so that current flows from A1(+) to A2(-). There are cases where the contactor will interrupt power in the opposite direction but please contact Sensata to confirm suitability. Direction of current flow is not relevant during make or when flowing on closed contacts. For bi-directional contactors, please contact Sensata.
- Applications with **capacitors** will require a pre-charge circuit.
- Electrical life rating is based on resistive load with 27µH maximum inductance in circuit. Because your application may be different, we suggest you test the contactor in your circuit to verify life is as required.
- End of life is defined as when the dielectric, insulation resistance or contact resistance exceeds the specifications listed.

Page 5