

### FEATURES

- > Low stable contact resistance for high carry current and low voltage drop
- > Low loss in RF circuits
- > Mounting options in any axis
- > Solder or convenient threaded HV connections

### PRODUCT SPECIFICATIONS

Contact & Relay Ratings	Units	G2L
<b>Contact Form</b>		C - latch
<b>Contact Arrangement</b>		SPDT
Contact Material (moveable/stationary)		molybdenum /copper
Dielectric		Vacuum
<b>Voltage, Test Max., Contacts &amp; to Base (15 µA Leakage Max.)</b> dc or 60Hz	kV Peak	17
<b>Voltage, Operating Max., Contacts &amp; to Base (15 µA Leakage Max.)</b>		
dc or 60 Hz	kV Peak	15
2.5 MHz	kV Peak	12
16 MHz	kV Peak	9
32 MHz	kV Peak	7
<b>Current, Load Switching</b>		Contact factory**
<b>Current, Continuous Carry Max</b>		
dc or 60 Hz	Amps	50
2.5 MHz	Amps	30
16 MHz	Amps	17
32 MHz	Amps	10
<b>Coil Hi-Pot (V RMS, 60 Hz)</b>	V	500
<b>Capacitance</b>		
Across Open Contacts	pF	.05
Contacts to Ground	pF	1
<b>Resistance, Contact Max @ 1A, 28 Vdc</b>	ohms	0.012
<b>Latch Time</b>	ms	15
<b>Reset Time</b>	ms	9
<b>Life, Mechanical</b>	cycles	1 million
<b>Weight, Nominal</b>	g (oz)	84 (3)
<b>Vibration, Operating, Sine (55-500 Hz Peak)</b>	G's	10
<b>Shock, Operating, 1/2 Sine11ms (Peak)</b>	G's	50
<b>Temperature Ambient Operating</b>	°C	-55 to +125

\*\* Consult factory for load switching applications.

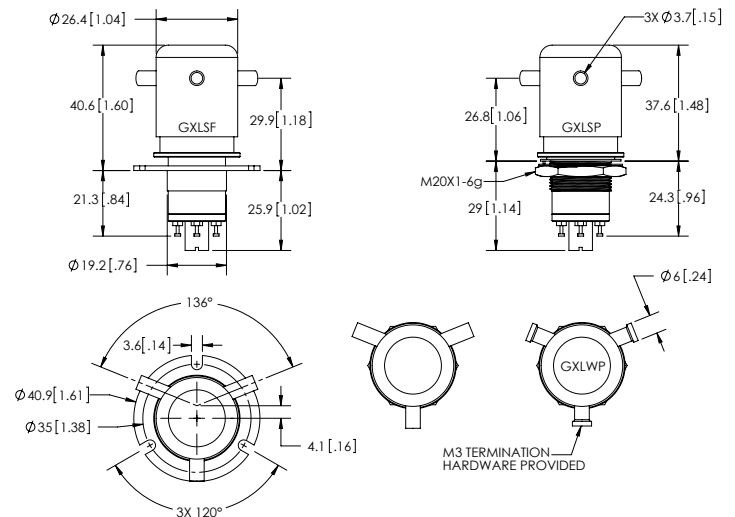

### COIL RATINGS

Nominal, Volts dc	26.5
Latch, Volts dc, Max.	16
Reset, Volts dc	1 - 10
Coil Resistance (Ohms ±10%)	

### PART NUMBER SYSTEM

G2L	S	P	
<b>High Voltage/Power Terminal Connections</b>	S = Solder Pot W = Screw		
<b>Mounting</b>		P = Through Panel F = Flange	
<b>Coil Voltage*</b>			Blank = 26.5 Vdc

\* Order the relay with the part number as shown. The latching "L" designator and the coil voltage will not appear in the P/N on the relay but will be indicated on the label that is on the base of the relay. Observe coil polarity.