

### FEATURES

- > RF efficient design for low signal loss
- > Identical performance mounted in any axis
- > Vacuum dielectric for low stable contact resistance
- > Low coil power
- > Meets or exceeds MIL-R-83725

### PRODUCT SPECIFICATIONS

Contact & Relay Ratings	Units	G47
Contact Form		B
Contact Arrangement		SPST-NC
Voltage, Test Max., Contacts & to Base (15 µA Leakage Max., dc or 60Hz)	kV Peak	9
Voltage, Operating Max., Contacts & to Base (15 µA Leakage Max.)		
dc or 60 Hz	kV Peak	8
2.5 MHz	kV Peak	7.5
16 MHz	kV Peak	7
32 MHz	kV Peak	5
<b>Current, Continuous Carry Max</b>		
dc or 60 Hz	Amps	12*
2.5 MHz	Amps	10
16 MHz	Amps	5
32 MHz	Amps	3
<b>Coil Hi-Pot (V RMS, 60 Hz)</b>	V	500
<b>Capacitance</b>		
Across Open Contacts	pF	1.2
Contacts to Ground	pF	1.2
<b>Resistance, Contact Max @ 1A, 28 Vdc</b>	ohms	0.03
<b>Operate Time</b>	ms	10
<b>Release Time</b>	ms	10
<b>Life, Mechanical</b>	cycles	2 million
<b>Weight, Nominal</b>	g (oz)	25 (0.09)
<b>Vibration, Operating, Sine (55-1000 Hz Peak)</b>	G's	10
<b>Shock, Operating, 1/2 Sine 11ms (Peak)</b>	G's	30
<b>Temperature Ambient Operating</b>	°C	-55 to +125

\* Consult factory for load switching applications.

### COIL RATINGS

Nominal, Volts dc	12	26.5
Pick-up, Volts dc, Max.	8	16
Drop-Out, Volts dc	.5 - 5	1 - 10
Coil Resistance (Ohms ±10%)	230	920

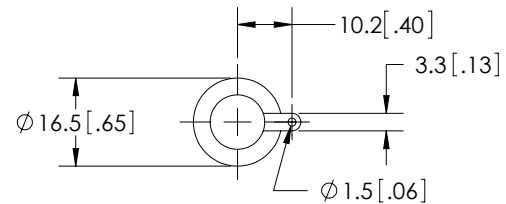
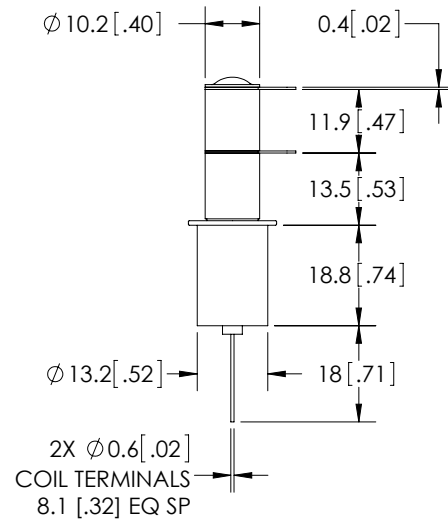
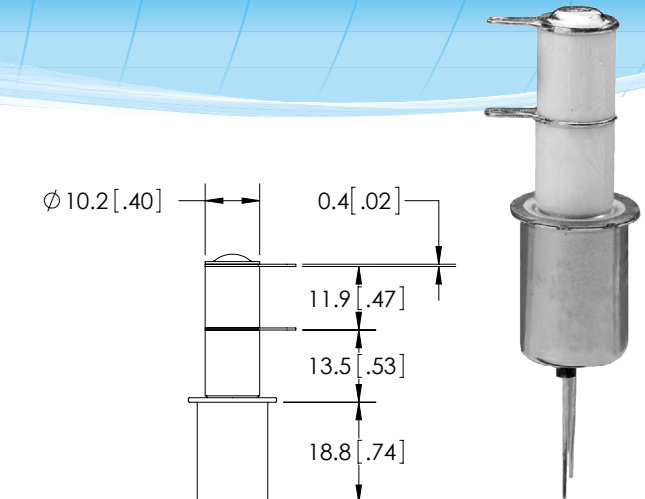

### 3-Hole Flange

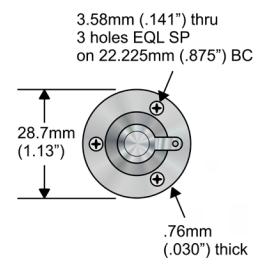

### PART NUMBER SYSTEM

G47B	3	3	4
<b>Coil Voltage</b>	2 = 12 Vdc, Bus Wire 3 = 26.5 Vdc, Bus Wire		
<b>High Voltage Connections</b>		3 = Solder Connection	
<b>Mounting</b>			2 = 3-hole Flange 4 = Std Flange