

FEATURES

- > Tungsten contacts improve power performance**
- > Gas dielectric is excellent for capacitive loads
- > Mounting options in any axis

PRODUCT SPECIFICATIONS

Contact & Relay Ratings	Units	GH6
Contact Form		C
Contact Arrangement		SPDT
Contact Material (moveable/stationary)		molybdenum /tungsten
Dielectric		Inert gas
Voltage, Test Max., Contacts & to Base (15 µA Leakage Max.) dc or 60Hz	kV Peak	10
Voltage, Operating Max., Contacts & to Base (15 µA Leakage Max.) dc or 60 Hz	kV Peak	8
Current, Load Switching		Contact factory**
Current, Continuous Carry Max dc or 60 Hz	Amps	8
Coil Hi-Pot (V RMS, 60 Hz)	V	500
Resistance, Contact Max @ 1A, 28 Vdc	ohms	0.02
Operate Time	ms	6
Release Time	ms	6
Life, Mechanical	cycles	2 million
Weight, Nominal	g (oz)	39 (1.4)
Vibration, Operating, Sine (55-500 Hz Peak)	G's	10
Shock, Operating, 1/2 Sine11ms (Peak)	G's	50
Temperature Ambient Operating	°C	-55 to +125

COIL RATINGS

Nominal, Volts dc	12	26.5	115
Pick-up, Volts dc, Max.	8	16	80
Drop-Out, Volts dc	.5 - 5	1 - 10	5 - 50
Coil Resistance (Ohms ±10%)	80	335	6000

PART NUMBER SYSTEM

GH6	
High Voltage/Power Terminal Connections	
Coil Voltage *	Blank = 26.5 Vdc -12Vdc = 12Vdc -115Vdc = 115Vdc

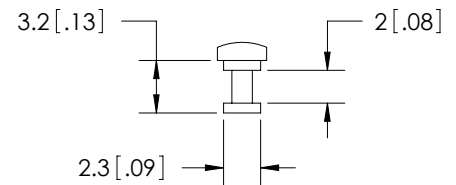
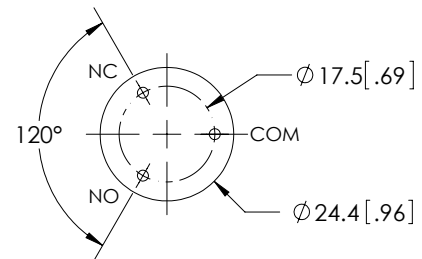
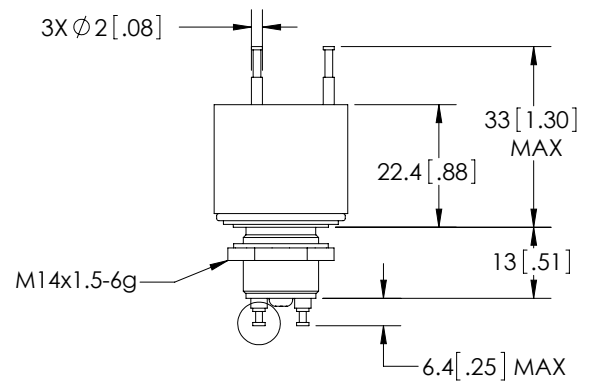

COIL DETAIL (3 : 1)

* Order the relay with the coil voltage in the part number as shown above. The coil voltage will appear on the coil plate near the coil terminals rather than in the P/N on the relay.

** Consult factory for load switching applications.