

**Key Features**

<b>EPIC® Seal</b>	Ceramic to metal braze. Gas filled hermetic chamber protects key components. Exceeds IP69K standard
<b>Temperature</b>	Tested to temperatures up to 200°C
<b>Contacts / Form</b>	Silver / SPST / NO
<b>Coil</b>	Efficient two coil design with no PWM or EMI emissions. Coil suppression built in
<b>High Shock and Vibration</b>	For rugged environments, off-road and tracked vehicles
<b>Installation</b>	Not direction sensitive
<b>Made in USA</b>	Designed and manufactured in the USA
<b>Reference</b>	MIL-R-6106, RoHS

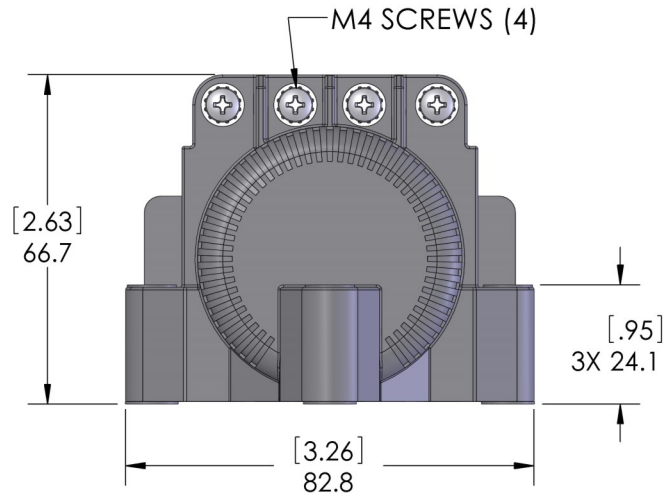

**Current Carry vs Time**  
 with 85°C terminal temperature rise

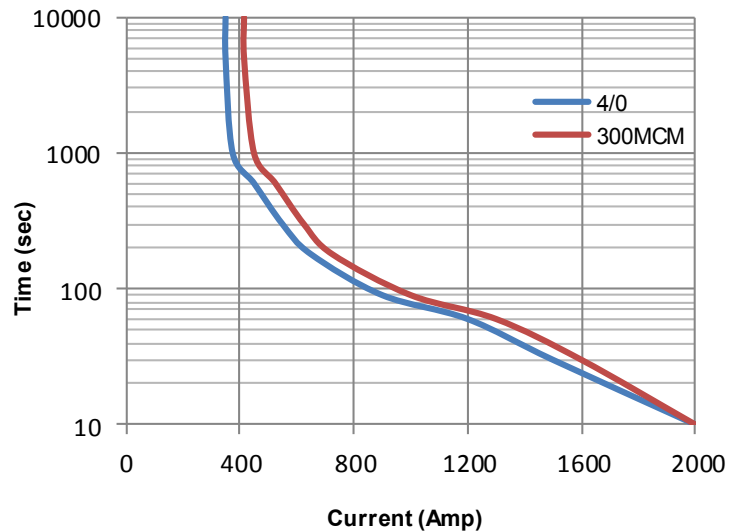

**Power Terminals**  
 Stainless M10 X 1.5 Stud  
 Stainless M10 X 1.5 Flanged Nut  
 Torque 9-10 Nm [80-90 in-lb]

**Mounting Hardware**  
 M5 [No. 10] Bolts (not incl.)  
 Torque 2-4 Nm [18-35 in-lb]

**Case Material**  
 25% GF Nylon 6/6, UL 94 V-0

<b>PIK-AS Austria GmbH</b> - Elektrotechnische Fabrikate -		AT-7433 Mariasdorf 140a
<a href="http://www.pikas.at">www.pikas.at</a>	<a href="mailto:office@pikas.at">office@pikas.at</a>	+43 3353 7613
Rev 6	9/24/15	© 2013 GIGAVAC, LLC Page 1 of 2 <b>MX34</b>

Technical Specification	
Continuous Current	400A w/ 300MCM (see graph on reverse)
Max Current—1 sec	3000A
Max Current—10 sec	2000A
Max Current—90 sec	1000A
Contact Voltage Drop (max)	150mV at 400A
Insulation Resistance (min)	100MΩ (50MΩ after life)
Dielectric Withstanding	1500VRMS (1050 VRMS after life)
Operate Time (max)	20 msec (include bounce)
Release Time (max)	12 msec
Weight	1.1 lb with hardware (500 grams)

**MX34 D**

**Coil Voltage:** \_\_\_\_\_

**B = 12V**  
**C = 24V**  
**F = 48V**

**Auxiliary Contacts:** \_\_\_\_\_

**Blank = none**  
**B = SPST, Normally Open**

Resistive Load Switching	
400A at 24 VDC	100,000 cycles
Mechanical Life	300,000 cycles
Fault Interrupt @ 28VDC	3000A

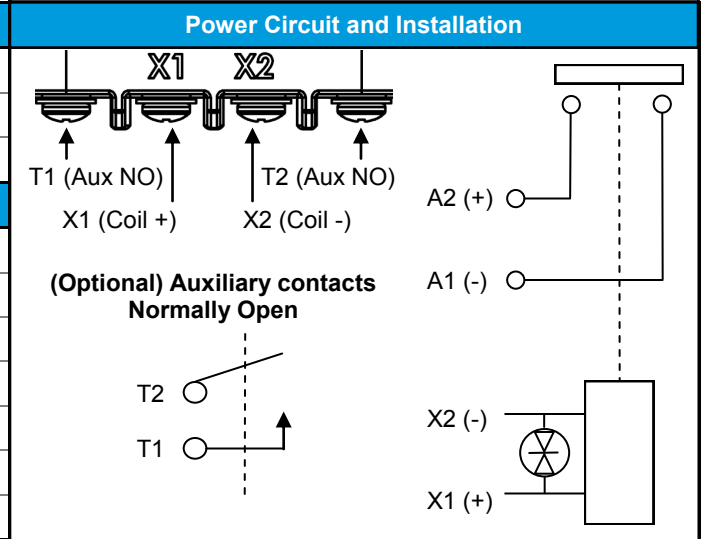

Environmental Specifications	
Seal	Hermetic, 10 E-9 atm cc/sec
Temperature Range	-55°C to +100°C
Shock	Sawtooth @ 20G, 11ms, ½ Sine @ 25G, 11ms
Vibration	10-2000 Hz, 20G
Water / Steam	2750 psi waterjet, 105 psi steam, boiling water
Salt Spray Corrosion	MIL-STD-810G
Resistant to corrosion, chemicals, and fungal growth	

Auxiliary contacts (optional) - Form A, SPST Normally Open	
Switching Current (max)	1A at 28VDC
Switching Current (min)	0.1mA at 5V

**Coil Ratings at 25°C**  
 \*Contact factory for additional coil voltages

Coil P/N Designation	B	C	F
Coil Voltage, Nominal	12 VDC	24 VDC	48 VDC
Coil Voltage, Max	16 VDC	32 VDC	64 VDC
Pick-Up Voltage, Max	8 VDC	16 VDC	40 VDC
Drop-Out Voltage	0.5 to 4 VDC	2 to 7.5 VDC	4 to 15 VDC
Pick-Up Current, Max (75ms)	3.9 A	1.6 A	0.97 A
Coil Current	0.23 A	0.097 A	0.042 A
Coil Power	2.8 W	2.3 W	2 W
Internal Coil Suppression	Transorb		
Coil Back EMF	55 V		125 V
Transients, Max (13ms)	±50 V		±75 V
Reverse Polarity	16 V	32 V	64 V



Options and Accessories	

<b>PIK-AS Austria GmbH</b> - Elektrotechnische Fabrikate -		AT-7433 Mariasdorf 140a
<a href="http://www.pikas.at">www.pikas.at</a>	<a href="mailto:office@pikas.at">office@pikas.at</a>	<b>+43 3353 7613</b>
Rev 6	9/24/15	© 2013 GIGAVAC, LLC Page 2 of 2 <b>MX34</b>